



LoFlow[®]

Series 'M' Milliflow[®] Piston Meters

T E C H N I C A L M A N U A L 118

INSTRUCTIONS FOR INSTALLATION, OPERATION
AND MAINTENANCE



WARRANTY CONDITIONS

1. Without prejudice to the restrictions stated hereinafter, the contractor guarantees both the soundness of the product delivered by him and the quality of the material used and/or delivered for it, insofar as this concerns faults in the product delivered which do not become apparent during inspection or transfer test, which the principal shall demonstrate to have arisen within 12 months from delivery in accordance with subarticle 1a, exclusively or predominantly as a direct consequence of unsoundness of the construction used by the contractor or as a consequence of faulty finishing or the use of poor materials.

1a. The product shall be deemed to have been delivered when it is ready for inspection (if inspection at the premises of the contractor has been agreed) and otherwise when it is ready for shipment.

2. Articles 1 and 1a shall equally apply to faults which do not become apparent during inspection or transfer test which are caused exclusively or predominantly by unsound assembly/installation by the contractor. If assembly/installation is carried out by the contractor, the guarantee period intended in article 1 shall last 12 months from the day on which assembly/installation is completed by the contractor, with the understanding that in this case the guarantee period shall end not later than 18 months after delivery in accordance with the terms of subarticle 1a.

3. Defects covered by the guarantee intended under articles 1, 1a and 2 shall be remedied by the contractor by repair or replacement of the faulty component either on or off the premises of the contractor, or by shipment of a replacement component, this remaining at the discretion of the contractor. Subarticle 3a shall equally apply if repair or replacement takes place at the site where the product has been assembled/installed. All costs accruing above the single obligation described in the first sentence, such as are not restricted to shipment costs, travelling and accommodation costs or disassembly or assembly costs insofar as they are not covered by the agreement, shall be paid by the principal.

3a. If repair or replacement takes place at the site where the product has been assembled/installed, the principal shall ensure, at his own expense and risk, that:

- a. the employees of the contractor shall be able to commence their work as soon as they have arrived at the erection site and continue to do so during normal working hours, and moreover, if the contractor deems it necessary, outside the normal working hours, with the proviso that the contractor informs the principal of this in good time;
- b. suitable accommodation and/or all facilities required in accordance with government regulations, the agreement and common usage, shall be available for the employees of the contractor;
- c. the access roads to the erection site shall be suitable for the transport required;
- d. the allocated site shall be suitable for storage and assembly;
- e. the necessary lockable storage sites for materials, tools and other goods shall be available;
- f. the necessary and usual auxiliary workmen, auxiliary machines, auxiliary tools, materials and working materials (including process liquids, oils and greases, cleaning and other minor materials, gas, water, electricity, steam, compressed air, heating, lighting, etc.) and the measurement and testing equipment usual for in the business operations of the principal, shall be available at the correct place and at the disposal of the contractor at the correct time and without charge;
- g. all necessary safety and precautionary measures shall have been taken and adhered to, and all measures shall have been taken and adhered to necessary to observe the applicable government regulations in the context of assembly/installation;
- h. the products shipped shall be available at the correct site at the commencement of and during assembly.

4. Defects not covered by the guarantee are those which occur partially or wholly as a result of:
 - a. non-observance of the operation and maintenance instructions or other than foreseeable normal usage;
 - b. normal wear and tear;
 - c. assembly/installation by third parties, including the principal;
 - d. the application of any government regulation regarding the nature or quality of the material used;
 - e. materials or goods used in consultation with the principal;
 - f. materials or goods provided by the principal to the contractor for processing;
 - g. materials, goods, working methods and constructions insofar as are applied at the express instruction of the principal, and materials or goods supplied by or on behalf of the principal.
 - h. components obtained from third parties by the contractor insofar as that party has given no guarantee to the contractor.

5. If the principal fails to fulfil any obligation properly or on time ensuing from the agreement concluded between the principal and the contractor or any agreement connected to it, the contractor shall not be bound by any of these agreements to any guarantee regardless of how it is referred to. If, without previous written approval from the contractor, the principal commences disassembly, repair or other work on the product or allows it to be commenced, then every agreement with regard to guarantee shall be void.

6. Claims regarding defects must be submitted in writing as quickly as possible and not later than 14 days after the discovery of such. All claims against the contractor regarding faults shall be void if this term is exceeded. Claims pertaining to the guarantee must be submitted within one year of the valid complaint on penalty of invalidity.

7. If the contractor replaces components/products under the terms of his guarantee obligations, the replaced components/products shall become the property of the contractor.

8. Unless otherwise agreed, a guarantee on repair or overhaul work carried out by the contractor or other services shall only be given on the correctness of the manner in which the commissioned work is carried out, this for a period of 6 months. This guarantee only covers the single obligation of the contractor to carry out the work concerned once again in the event of unsound work. In this case, subarticle 3a shall apply equally.

9. No guarantee shall be given regarded the inspection conducted, advice given and similar matters.

10. Alleged failure to comply with his guarantee commitments on the part of the contractor shall not absolve the principal from his obligations ensuing from any agreement concluded with the contractor.

11. No guarantee shall be given on products which form a part of, or on work and services on, goods older than 8 years.

1.	PREFACE	5
1.1	GENERAL.....	5
1.2	SYMBOLS	5
1.3	COPYRIGHT	5
2.	INTRODUCTION	6
2.1	BEFORE INSTALLING FLOWMETER.....	6
2.2	PRINCIPLE OF OPERATION	7
3.	INSTALLATION.....	8
3.1	GENERAL.....	8
3.2	SYSTEM LAYOUT RECOMMENDATIONS.....	8
3.2.1	Liquid filter.....	8
3.2.2	Environmental protection.....	8
3.2.3	Supporting the flowmeter.....	9
3.2.4	Bypass piping arrangement	9
3.2.5	To prevent the flowmeter from emptying	9
3.2.6	To prevent measuring air	10
3.3	TO INSTALL FLOWMETER	10
3.4	OPTIONAL PULSE TRANSMITTER	12
3.4.1	Technical specification of pulse transmitters.....	12
3.4.2	Intrinsic safe operation.....	12
3.5	OPTIONAL PULSE DISCRIMINATOR.....	13
3.6	ELECTRIC CONNECTION DIAGRAMS.....	13
3.6.1	Connection cable	13
3.6.2	Internal connections at totaliser	14
3.6.3	Internal wiring of connector plug	14
3.6.4	External connections at pulse transmitter box.....	15
4.	START-UP AND OPERATION	17
4.1	START-UP PROCEDURES	17
4.1.1	Initial start-up of a flowmeter system with bypass	17
4.1.2	Initial start-up of a flowmeter system without bypass	18
4.2	OPERATION OF COUNTERS	19
4.2.1	Totaliser.....	19
4.2.2	FlowCount Rate-Totaliser.....	19
5.	MAINTENANCE.....	20
5.1	GENERAL.....	20
5.2	ACCURACY CHECK	20
5.3	CHECK OF TOTALISER	20
6.	TROUBLE SHOOTING	21
6.1	TROUBLE SHOOTING CHART.....	21
7.	SERVICE AND REPAIR INSTRUCTIONS.....	23
7.1	GENERAL.....	23
7.2	TO REMOVE FLOWMETER FROM PIPING SYSTEM.....	23
7.3	CONDITIONS FOR RETURN OF GOODS	24
8.	DIMENSIONAL DRAWINGS	26

1. PREFACE

1.1 GENERAL

This manual contains installation, operation and maintenance instructions for VAF Liquid flowmeters Model LoFlow® Series 'M' Milliflow®.

This manual contains important information for the installer, the operator and for your maintenance department.



To ensure safe and correct installation and operation of your VAF flowmeter study this manual carefully before starting operations.

For associated equipment supplied by VAF Instruments B.V. refer to the documentation included with those products.

For any additional information contact:

VAF Instruments B.V.
Vierlinghstraat 24, NL-3316 EL Dordrecht
P.O. Box 40, NL-3300 AA Dordrecht
The Netherlands

Tel. +31 78 618 31 00
Fax +31 78 617 70 68
E-mail: sales@vaf.nl
Internet: www.vaf.nl

or your local authorized VAF dealer.

1.2 SYMBOLS

The symbols below are used to call attention to specific types of information.



A warning to use caution! In some instances, personal injury or damage to the flowmeter or control system may result if these instructions are not followed properly.



An explanation or information of interest.

1.3 COPYRIGHT

This manual is copyrighted with all rights reserved. No part of this manual may be copied or reproduced by any means without written permission of VAF Instruments B.V.

While every precaution has been taken in the preparation of this manual, no responsibility for errors or omissions is assumed. Neither is any liability assumed for damages resulting from the use of the information contained herein. Specifications can be changed without notice.

LoFlow® and Milliflow® are registered trademarks of VAF Instruments B.V.

2. INTRODUCTION

2.1 BEFORE INSTALLING FLOWMETER

1. Identify your flowmeter by comparing the type number on the instrument text plate with the description on the packing list.
2. Record text plate data in the relevant space of figure 1.



Always quote type and serial numbers when contacting the factory or your local VAF service representative.

3. Ensure that the flowmeter is suitable for your process conditions.



Never exceed the capacity, temperature and pressure limits specified on the text plate of the flowmeter.



Consult the factory if the flowmeter must be used for a different liquid than originally ordered.

4. Store the flowmeter in a safe place. Do not remove dust caps until just before installation.

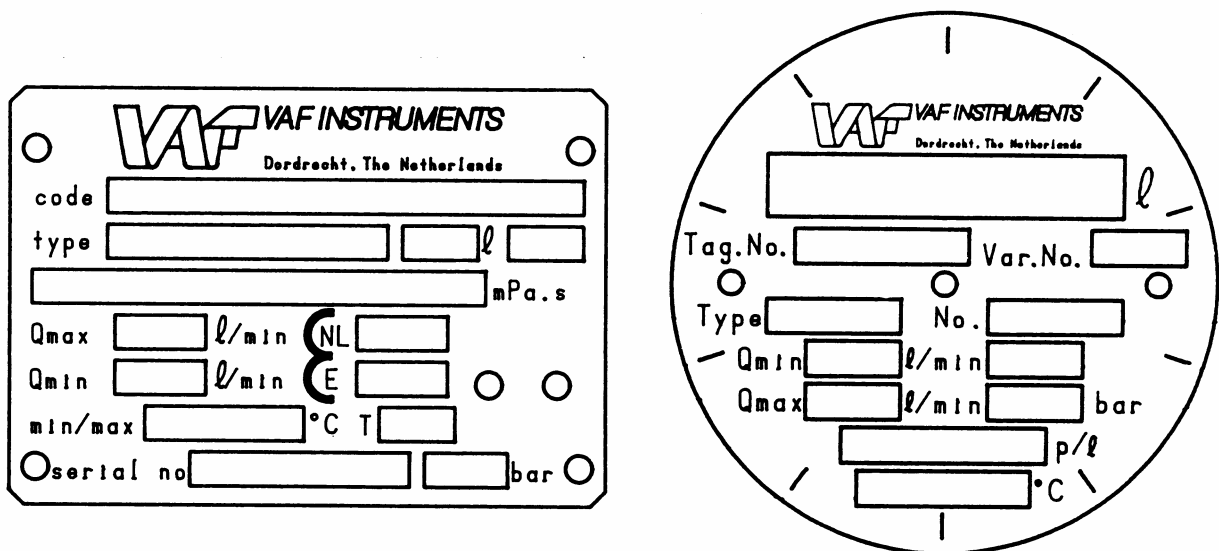

Fig. 1, Examples of text plates on pulse transmitter box (left) and totaliser (right).

2.2 PRINCIPLE OF OPERATION

Operating on the positive displacement principle, the flowmeter consists of four radial pistons, actuated in turn by the head pressure of the liquid. The pistons are linked to a crankshaft which is connected by a magnetic coupling to an LCD type FlowCount Rate-Totaliser, a mechanical totaliser with or without pulse transmitter, or a non-indicating pulse transmitter.



Note:

These flow meters are subject to P.E.D. (Pressure Equipment Directive) category 3.3.

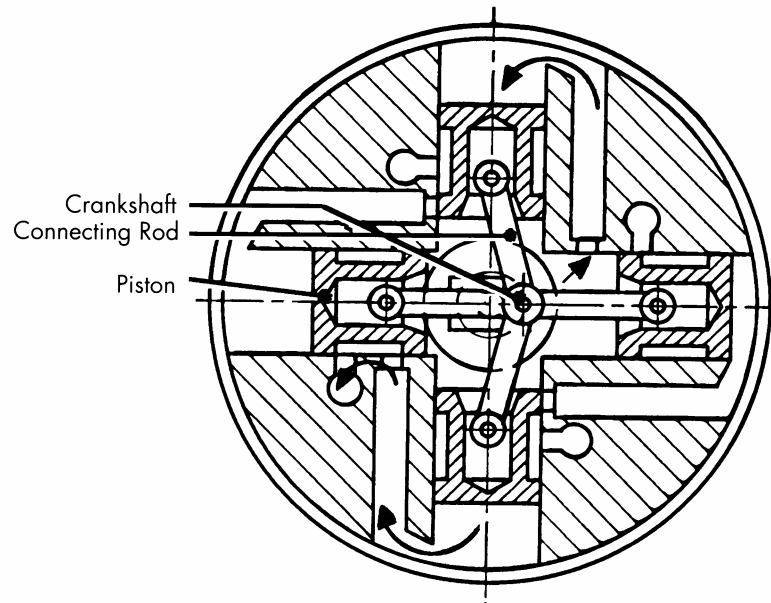

Fig. 2, Sectional view of Milliflow meter

3. INSTALLATION

3.1 GENERAL

1. Read this section carefully before installing the flowmeter.
2. A VAF flowmeter is a precision instrument. Handle it with care and store the flowmeter in a safe, dry and dust-free place.
3. No special tools are required to install the flowmeter. Ensure that your standard tools are fit for the job.
4. The sound level of a working flowmeter will always be lower than 70 dB(A).
5. Make sure the working environment is clean. Ensure that no dirt can enter the flowmeter.



Cautions

6. Always use personal protective means when working with hot, aggressive and toxic process liquids.
7. Ensure that local safety regulations are met when installing and operating the flowmeter.
8. The flowmeter body will maintain the same temperature as the process liquid. Take measures to avoid personal injury from touching a hot flowmeter.

3.2 SYSTEM LAYOUT RECOMMENDATIONS

3.2.1 Liquid filter

The liquid to be measured must be clean and free from air, gas or dirt. Solid particles may cause excessive wear. It is recommended to install a liquid filter with a mesh width of ≤ 0.05 mm at the inlet of the flowmeter. If necessary also install a suitable deaerator.



VAF Instruments B.V. will not be responsible for any damage to flowmeters and accessories caused by foreign particles in the process liquid.

3.2.2 Environmental protection

The flowmeter must be protected against aggressive and heavily polluted environmental conditions. The ambient temperature should be within the range of -15 to 55°C. For liquid temperature limits see textplate on flowmeter or figure 1.

3.2.3 Supporting the flowmeter

The flowmeter must never be used to support the piping or other system components. The flowmeter and its liquid connections must be protected against strain or mechanical vibrations. Either the flowmeter must be supported by the process piping, or both the pipeline and the flowmeter must be supported.

1. Install suitable pipe brackets at each side of flowmeter (Fig. 5).

 The flowmeter should be accessible from all sides for easy inspection and servicing.

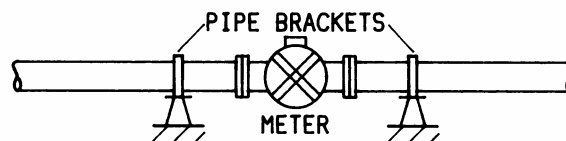



Fig.3, Supporting the flowmeter

3.2.4 Bypass piping arrangement

A bypass with manual block valves is recommended so that the meter can be serviced without interrupting the flow in the system (Fig. 6).

 A bypass may not be allowed when the flowmeter is used for custody transfer purposes.

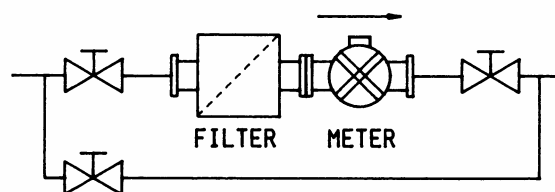

Fig. 4, Bypass piping arrangement

3.2.5 To prevent the flowmeter from emptying

To prevent the flowmeter from emptying or siphoning, maintain a back-pressure downstream of the meter so that it always remains full of liquid. This can be done by raising the pipe line downstream of the flowmeter, by installing a back-pressure valve, or by other suitable method.

3.2.6 To prevent measuring air

Accurate measurement is only possible if it is not influenced by the presence of gas or air. When the process liquid contains gas or air a deaerator should be fitted upstream of the flowmeter.

3.3 TO INSTALL FLOWMETER

1. Remove dust caps from inlet and outlet connections of flowmeter.



Note that there may be some ShellSol-T calibration liquid left in the flowmeter. ShellSol-T is a flammable liquid (hydrocarbons, N.O.S. (solvent naphtha). EEC No. 265-067-2, MITI No. 9-1699, CAS No. 64741-65-7.

2. Install the flowmeter in a horizontal pipe section, as shown in figures 5, 6 or 7, such that the counter or pulse transmitter box is on top.

CAUTION:



Do **NOT** install the flowmeter as illustrated in figures 8, 9 and 10.



NOTES:

- An arrow on the flowmeter body indicates the direction of the flow.
- To facilitate reading the counter may be turned in 90 degree increments by loosening four M4 hex.head bolts.
- The flowmeter should be accessible from all sides for easy reading and servicing.

CORRECT INSTALLATION

WRONG INSTALLATION

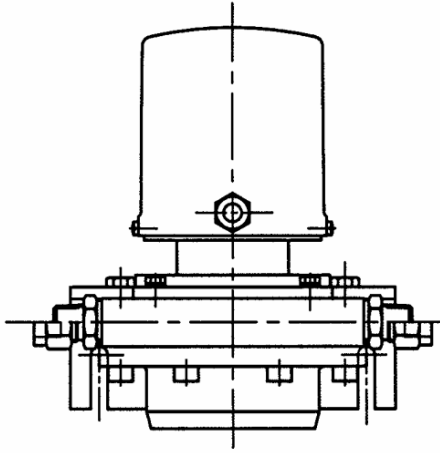

Fig. 5

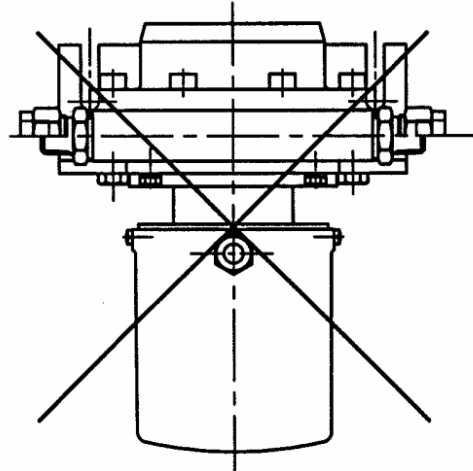

Fig. 8

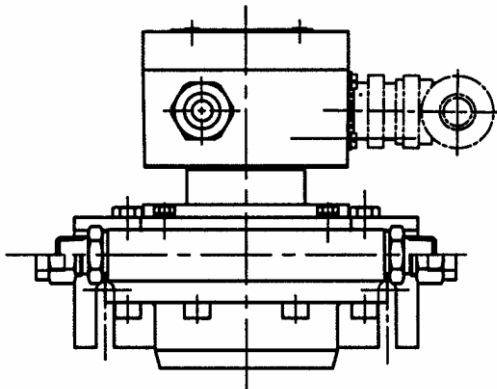

Fig. 6

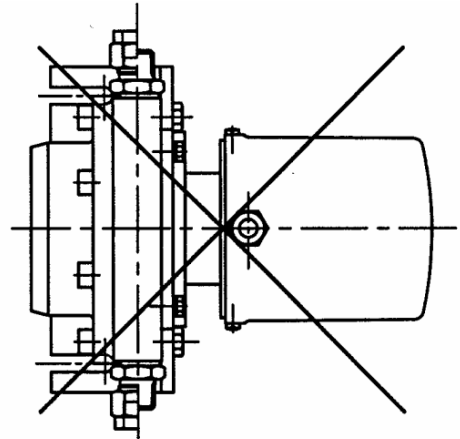

Fig. 9

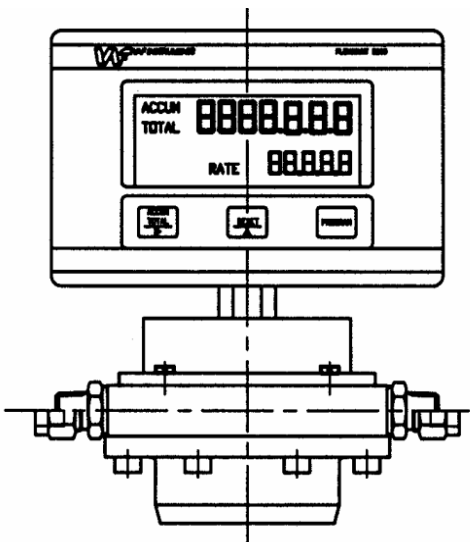

Fig. 7

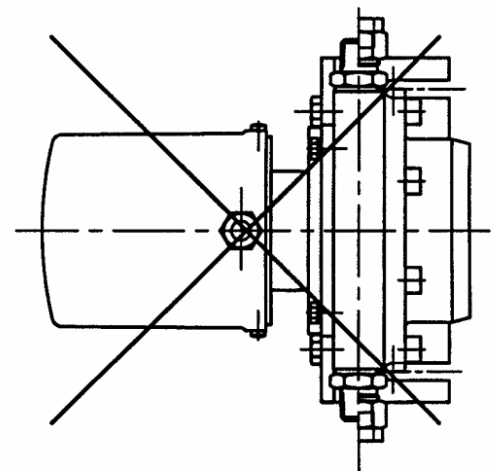

Fig. 10

3.4 OPTIONAL PULSE TRANSMITTER

If the flowmeter is equipped with a totaliser, the internal connections of the cable connected to the flowmeter are as shown in figure 11. The number of generated output pulses/litre is stamped on the dataplate of the totaliser.

If the flowmeter is equipped with a pulse transmitter box (instead of a totaliser), the number of generated output pulses is stamped on the dataplate of the pulse transmitter box.

See figures 11 to 16 for connection diagrams.

3.4.1 Technical specification of pulse transmitters

Inductive type	1 or 2 passive proximity switches according DIN 19234 (NAMUR). Protection class IP55, intrinsically safe acc. PTB No. 99 ATEX 2219X and Cenelec EEx ia/ib IIc T6, if used with suitable zener-barrier. Max. operating temperature 75°C. Supply voltage 8.2 VDC.
Incremental type	Installed in a pulse box fitted to the flowmeter. Includes pulse discriminator. Supply voltage 12-35 VDC. Max. frequency 5 kHz. Protection class IP55. Max. operating temperature 120°C.

3.4.2 Intrinsic safe operation

To meet the standards for intrinsically safe operation according DIN 19234 (NAMUR), zener-barrier(s) (Stahl 9001/3-158-150/00, Pepperl & Fuchs EGT-101-0, or equivalent) must be installed between the flowmeter and the associated data processing instrumentation. Consult VAF Instruments B.V. if further information on zener-barriers is required.

3.5 OPTIONAL PULSE DISCRIMINATOR

The pulse discriminator is housed in the pulse transmitter box of a non-indicating flowmeter. The discriminator is used in situations where, as a result of vibrations or pulsations in the liquid piping, it is possible for the flowmeter to rotate in the reverse direction. This may result in the generation of spurious pulses by the electric transmitter. By using a double pulse transmitter in the flowmeter, generating two identical pulse signals with a phase shift of 90 degrees, these measurement errors will be eliminated by means of the pulse discriminator. The discriminator comprises a small printed circuit board which also contains a pulse amplifier. This makes the device suitable for direct connection to, for instance, an electromechanical counter or to a relay for further pulse processing.

Electric connections	3-wire screw terminal.
Supply voltage	12 - 35 VDC
Power consumption	2 VA at 35 VDC (no load)
Input signal	2 NAMUR pulse transmitters or incremental encoders
Pulse memory	up to 15 fault pulses
Connections	6-pin connector or cable gland PG 13.5
Max. working temp.	55°C
Output signal	Open collector, current sink . I_{max} 100 mA, U_{max} 35 VDC
Protection class	IP55, DIN 40050
Approved	CE

3.6 ELECTRIC CONNECTION DIAGRAMS

The electrical connections of the pulse transmitter are as shown in figures 11 to 16.

For electrical connections between flowmeter and associated electronic processing instrumentation, reference is made to the technical manuals supplied with these electronic instruments.

3.6.1 Connection cable

Each pair of leads between the pulse transmitter and the connected signal processing instrumentation must be screened separately, as otherwise counterfeit pulses might be induced by external electromagnetic fields.

Use shielded cable with a diameter of 6 to 8 mm and a wire diameter of max. 0.8 mm. The screen must NOT come into contact with the flowmeter. In the connected instrument the screen must be connected to the system earth or, in absence of the latter, to the zero connection of the pulse input terminals.

3.6.2 Internal connections at totaliser

Figure 11 shows how the pulse generator(s), when installed in the totaliser, is/are internally connected.

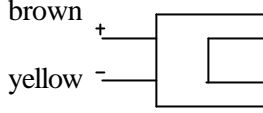
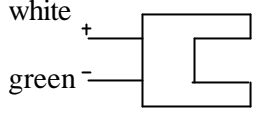
Wiring of pulse generators:		
Connections of pulse transmitter: 1 low frequency pulse transmitter * 1 high frequency pulse transmitter * 2 low frequency pulse transmitters 2 high frequency pulse transmitters 1 low+1 high frequency pulse transmitter	low: <input type="checkbox"/> low: <input type="checkbox"/> high: <input type="checkbox"/> low: <input type="checkbox"/>	high: <input type="checkbox"/> low: <input type="checkbox"/> high: <input type="checkbox"/> high: <input type="checkbox"/>

*Low frequency includes 10 or 100 pulses/litre (meter model M31) and 1 or 10 pulses/litre (meter model M32). Other pulse rates are high frequency type.

Fig. 11, Wiring of pulse generators inside totaliser

3.6.3 Internal wiring of connector plug

When the pulse output cable from the totaliser is provided with a 6-pole connector, the internal wiring is as shown in figure 12.

	6-pole connector	Cable
High 1 +	A	White
-	B	Green
High 2 +	C	Brown
-	D	Yellow
Low 1 +	E	Brown
-	F	Yellow
Low 2 +	C	White
-	D	Green

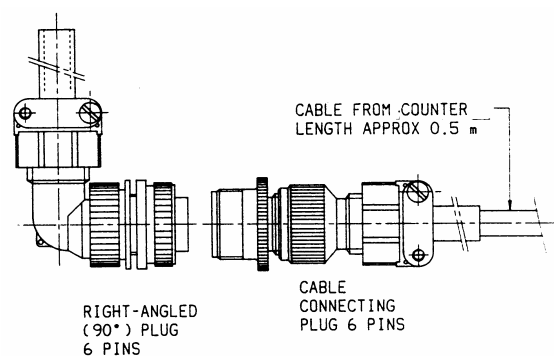

Fig. 12, Internal wiring of connector plug

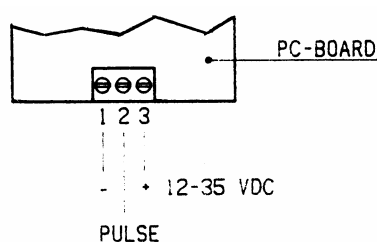
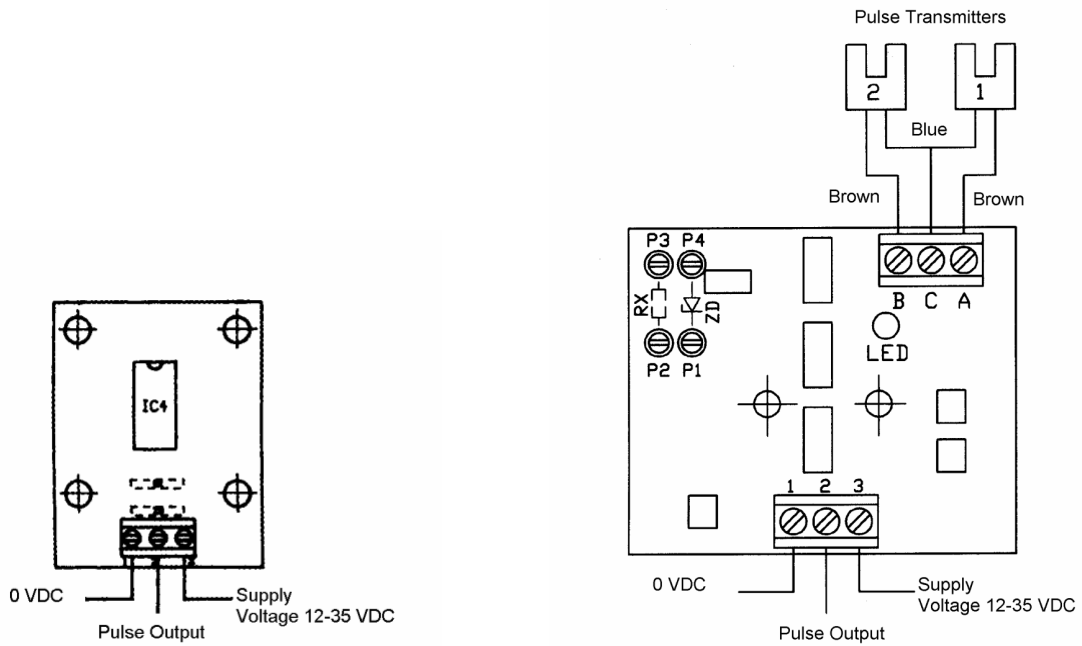

Fig. 13, External connections of flowmeter with pulse discriminator or incremental pulse encoder in pulse box with Pg 13.5 cable gland.

3.6.4 External connections at pulse transmitter box



Pulse output	Resistor (Rx)	Zener diode (Zd)
Open-Collector	-	-
5 V pulse	* 2k4	4V7 - 0,4 W
12 v pulse	* 1k4	12 V - 0,4 W

* supply voltage 24 VDC

$$\text{Calculation: } Rx = \frac{\text{supply voltage} - \text{desired pulse voltage}}{0,008}$$

Fig. 14, Non-indicating flowmeter with inductive magnetic pulse transmitter

Fig. 15, Non-indicating flowmeter with pulse transmitters and pulse discriminator

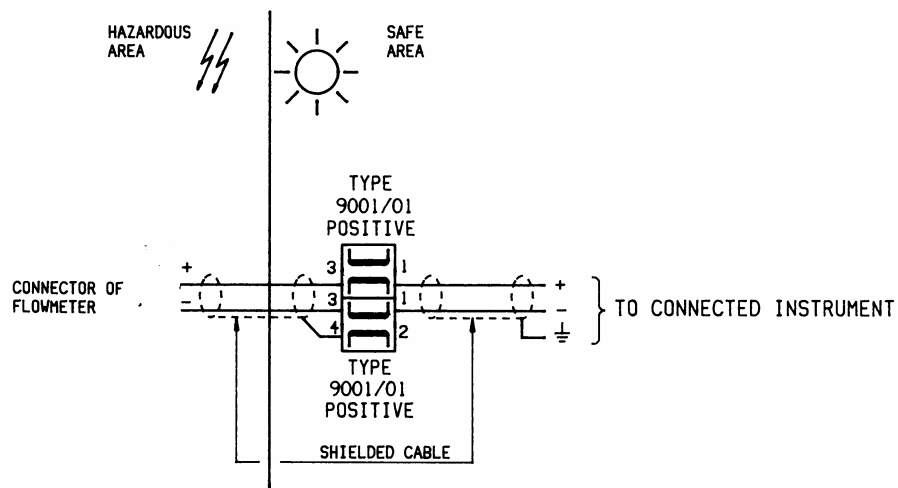

Fig. 16, External connections to safety barrier

4. START-UP AND OPERATION

4.1 START-UP PROCEDURES

Before initial start-up of a flowmeter system, or when taking the installation again into use after a major repair or revision of the piping system, the following procedures are recommended.

1. Remove filter element of liquid filter installed ahead of flowmeter.
2. Remove flowmeter from liquid system and replace it by a pipe piece.
3. Flush entire liquid system to ensure that all dirt and other foreign matter that could damage the flowmeter have been removed.

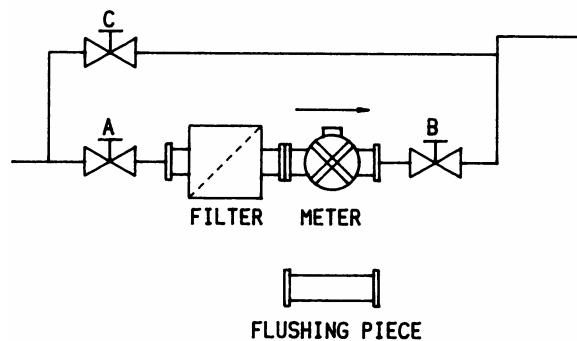

Fig. 17, Flowmeter system with bypass

4.1.1 Initial start-up of a flowmeter system with bypass

1. Close valves A, B and C (Fig. 17).
2. Remove flushing pipe piece. Re-install flowmeter and filter element.
3. Start pump and/or open storage tank valve. Prevent pressure pulsations.
4. Slowly open bypass valve C completely.
5. Open valve A slightly (5-10%).
6. Slowly open valve B. Dependent on the internal resistance in the system, the flowmeter may start running. If it does, limit the flow to approx. 20% of its capacity.



CAUTION: Flowmeters with ferralium cylinder linings must NEVER run dry, or serious damage will occur.

7. Slowly close bypass valve C until flowmeter just starts running.
Let the flowmeter run on this limited flow for a couple of minutes, to ensure that no air or gas will be left in the flowmeter.
8. Slowly open valve A, and if necessary also valve B, completely.
9. Slowly close valve C completely.



NEVER exceed maximum flowrate (Q_{\max} , see text plate of flowmeter)

4.1.2 Initial start-up of a flowmeter system without bypass

1. Close valves A and B (Fig. 18).
2. Remove flushing pipe piece. Re-install flowmeter and filter element.
3. Start pump and/or open storage tank valve.
4. Open valve A slightly (5-10%).
5. Slowly open valve B until flowmeter just starts running.
Let the meter run on this limited flow for a couple of minutes, to ensure that no air or gas will be left in the flowmeter.
6. Slowly open valve B completely.
7. Slowly open valve A completely.



NEVER exceed maximum flowrate (Q_{\max} , see text plate of flowmeter)

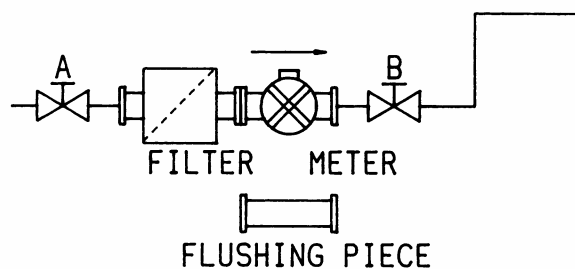

Fig. 18, Flowmeter system without bypass

4.2 OPERATION OF COUNTERS

This section only contains concise operating procedures. For additional functional description of counters separate technical manuals can be ordered from the Literature Department of VAF Instruments B.V.

4.2.1 Totaliser

The totaliser requires no operation.

4.2.2 FlowCount Rate-Totaliser



Fig.19, FlowCount Rate Totaliser

The Model E200 FlowCount Rate Totaliser is fully programmed in the factory, in accordance with the flow data supplied by the customer. The instrument will display rate, resetable total and accumulated total. FlowCount is an indicating instrument and may optionally be equipped with a 4-20 mA output, or a DC power input and flow alarm.

1. The accumulated total is displayed by pressing the [ACCUM TOTAL] key.
2. The resetable total can be reset at any time by pressing the [RESET] key.
3. The flow rate is continuously displayed.

The instrument also has a display test mode which can be entered by simultaneously pressing all three front panel keys, followed by pressing the [PROGRAM] key. All segments of the display will then show.

To exit the test mode, press the [ACCUM TOTAL] key and while still holding, simultaneously press the [RESET] and [PROGRAM] keys.



A technical manual with more details is supplied with each instrument.

5. MAINTENANCE

5.1 GENERAL

Under normal operating conditions the flowmeter requires no maintenance other than:

- * Periodic accuracy check. Refer to section 5.2;
- * Check of the totaliser (if supplied). Refer to section 5.3.

5.2 ACCURACY CHECK

The calibration interval will depend on the nature of the process liquid and the operating conditions. The table below applies if:-

- * the process liquid is clean and non-abrasive;
- * a liquid filter with correct mesh width has been installed at the flowmeter inlet.

Meter type Calibration interval (litres)

M31	1×10^5
M32	1×10^6

5.3 CHECK OF TOTALISER

The totaliser should be inspected:-

- * every two years when the flowmeter is installed in a normal environment;
- * every year when the flowmeter is installed in a hot, humid or dusty environment.

To check counter:

1. Remove three M3 cross head screws and lift off cap.
2. Inspect gear train for wear.



Be careful not to damage any installed pulse transmitter(s).
Do not lubricate plastic parts.

6. TROUBLE SHOOTING

6.1 TROUBLE SHOOTING CHART

PROBLEM: The flowmeter does not indicate any flow, although the liquid is flowing.

POSSIBLE CAUSE:

(perform a check in the following order):

1. The valve in the bypass line is still open.
2. The totaliser or FlowCount Rate-Totaliser malfunctioning.

SOLUTION:

1. Close bypass valve.

2.Totaliser:

Remove counter from flowmeter.

Rotate counter drive shaft with finger to see if counter runs smoothly.

FlowCount:

Is battery empty ?

Refer to trouble shooting section of manual supplied with instrument.

Continue with next step if this does not solve the problem.

3. Inner parts of flowmeter may be stuck or broken. 3.Return flowmeter to factory or authorized local VAF service representative

PROBLEM: The flowmeter does not indicate any flow and no liquid is passing through the flowmeter.

POSSIBLE CAUSE:

SOLUTION:

(perform a check in the following order):

- | | |
|--|---|
| 1. Obstructions in the liquid piping, blocking the flow. | Check for obstructions, e.g. closed valves.
If this does not solve the problem, proceed with next step. |
| 2. The dust cap in the inlet and/or outlet connection of the flowmeter was not removed when the flowmeter was installed in the process line. | Remove dust cap(s) and check the flowmeter for damage. If there are no visible signs of damage, proceed with next step. |
| 3. Dirt is blocking the inner parts of the flowmeter. | Flush the flowmeter with a suitable solvent.

If this does not solve the problem, return flowmeter to factory or nearest authorized VAF service representative. |
| 4. Inner parts of flowmeter may be stuck or broken. | Return flowmeter to factory or nearest authorized VAF service representative. |

7. SERVICE AND REPAIR INSTRUCTIONS

7.1 GENERAL

This chapter describes the procedures to be followed when a flowmeter must be removed from the process line for service or repair.

When a flowmeter is returned to VAF or authorized service representative, it must be accompanied by a duly filled out instruction form. See example in paragraph 7.3.

7.2 TO REMOVE FLOWMETER FROM PIPING SYSTEM



When removing a flowmeter from the piping system precautions must be taken to prevent personal injuries and damage to the flowmeter and process control installation.

Always wear protective clothing when the flowmeter contains a toxic or aggressive fluid.

The flowmeter body will maintain the same temperature as the process liquid. Take measures to avoid personal injury from touching a hot flowmeter.

1. Shut off flow through flowmeter.
2. Remove any electrical connections from flowmeter.
3. Empty piping system.



Do not empty piping system by blowing through with steam or air, otherwise flowmeter will be overspeded.

4. Reduce pressure in flowmeter to atmospheric level.
5. Remove flowmeter from piping system.



When the flowmeter is removed from the piping system there will be some liquid left in its measuring chamber.

6. Hold meter inlet in downward position and let flowmeter leak out for approximately ten minutes.
High viscosity liquids will perhaps require more time. Rinsing with a suitable solvent may be of help.
7. If flowmeter must be stored or returned to VAF or local service representative:
 - a) Flush flowmeter with a non-toxic, non-aggressive fluid;
 - b) Plug inlet and outlet ports of flowmeter;
 - c) Follow instructions in para 7.3.

7.3 CONDITIONS FOR RETURN OF GOODS

Return shipments of goods to VAF Instruments B.V. or local service agent must meet the following conditions:

1. The shipment must be accompanied by a check list giving full information about the reason for return and further instructions. See example on next page.
2. The flowmeter must be internally and externally cleaned and adequately preserved. It must be free from risks of fire, explosion and toxic matters which may cause a hazardous situation or personal injury.
3. Flowmeter inlet and outlet connections must be plugged so that no liquid can leak out of the instrument.
4. Goods must be sent c.i.f. destination.

Example of sheet to accompany a return shipment to factory or service agent.

Sheet to be filled out in English language

Sender

Company Name	_____	Contact Person	_____
Street	_____	Department	_____
Postal Code	_____	Telephone	_____
City	_____	Telefax	_____
Country	_____	E-mail	_____

Shipping address for return of goods to user (if different from above mentioned)

Reason for return

Repair Warranty Claim Calibration
 Other: _____

Type of flow meter (*see nameplate on instrument*)

Code / Type: _____
Serial Number: _____

Liquid Data

Process Liquid (trade name or chemical composition): _____
Liquid properties:
 harmless toxic explosion dangerous inflammable
Flow rate [l/min] minimal _____ nominal _____ maximum _____
Operating pressure: _____ Operating temperature: _____
Specific gravity: _____ Viscosity: _____

Description of Complaint / Work to be performed

Safety Precautions

The flow meter has been emptied
 The flow meter has been internally cleaned and preserved using _____
 Inlet- and outlet ports have been plugged

Recommended cleaning fluid: _____
Recommended safety precautions before opening of flow meter: _____

Installation date: _____ Failure date: _____
Date & Signature: _____ Name & Title: _____

8. DIMENSIONAL DRAWINGS

Except where noted all dimensions are in millimetres. Drawings of meter versions not shown here are available on application.

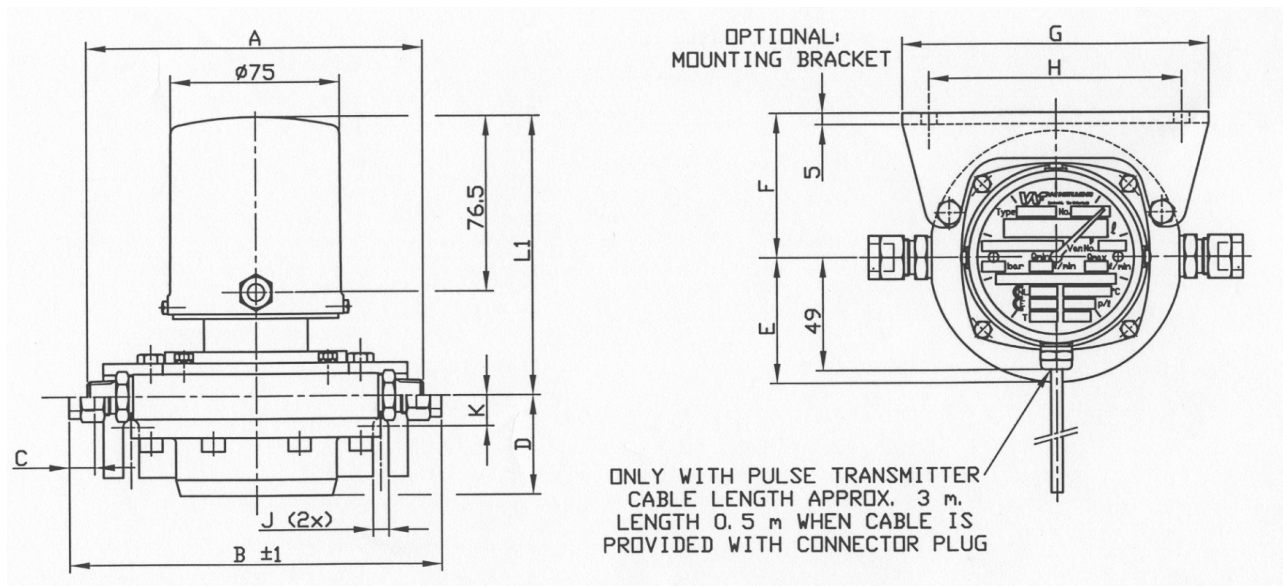

Fig. 20, Milliflow meters PN 25 and PN 35 with totaliser and optional inductive pulse transmitter
VAF Drawingnr.0811-1615-3

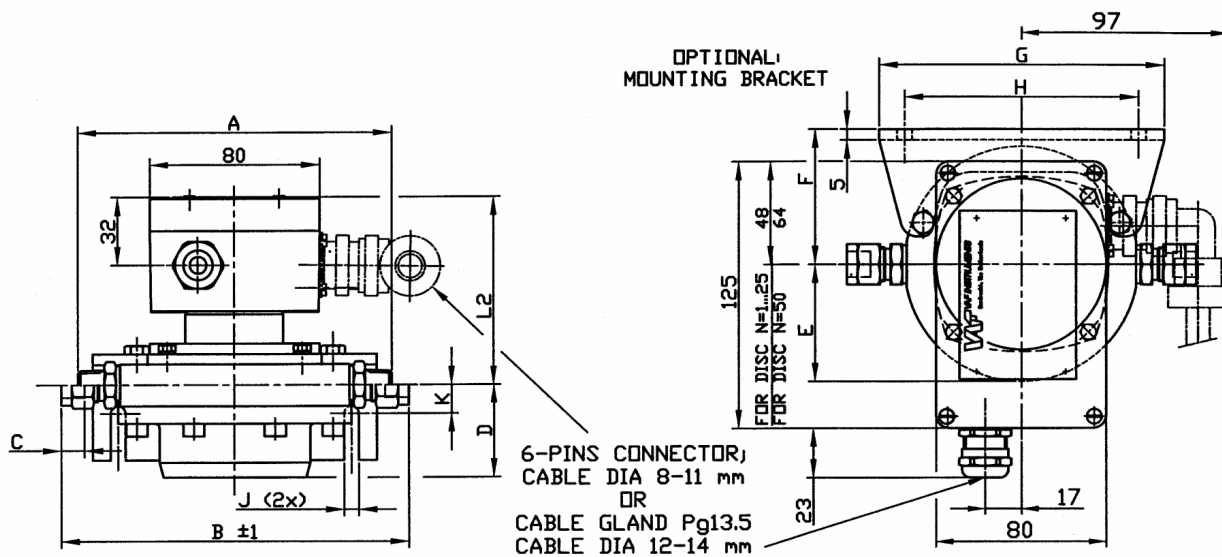
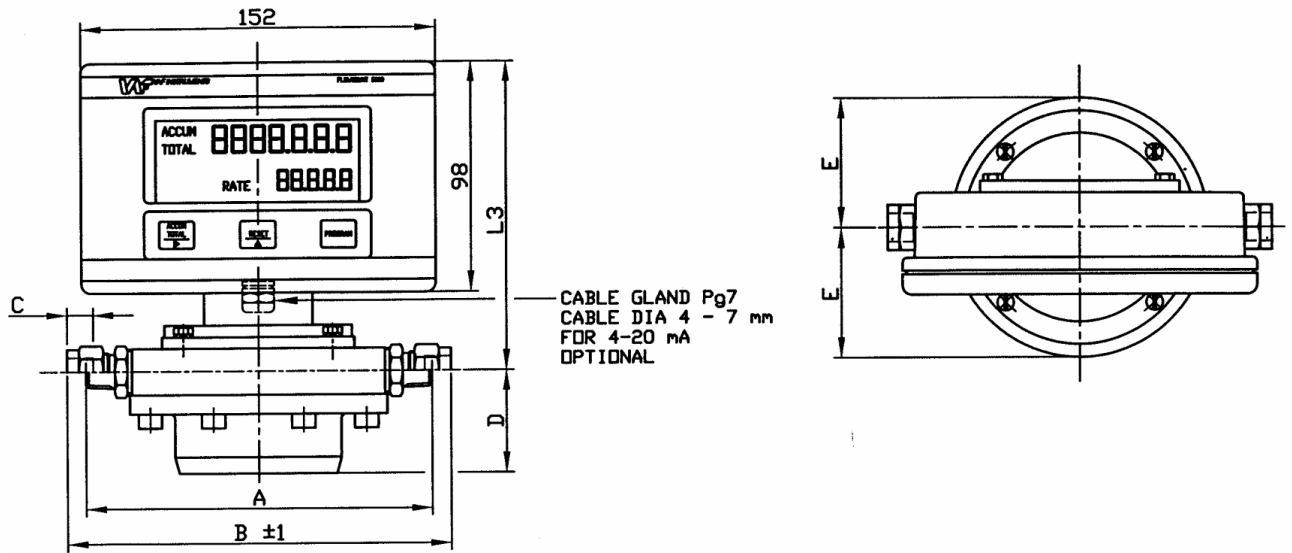

Fig. 21, Milliflow meters PN 25 and PN 35 with non-indicating inductive or incremental pulse transmitter
VAF Drawingnr.0811-1618-3



MODEL No.	CONNECTIONS SIZE						D	E	F	G	H	J	K	L1	L2	L3	WEIGHT MAX. kg
	1/4"	3/8"	PIPE COUPLINGS														
	NPT	NPT	8 mm		12 mm												
A	A	B	C	B	C												
M31	148	---	158	8	164	11	44	55	63	134	110	7	14	121	92	146	4
M32	---	207	---	-	226	11	76	85	93	190	160	10	12	123	94	148	11

Fig. 22, Milliflow meters PN 25 and PN 35 with FlowCount Rate Totaliser
VAF Drawingnr.0811-1613-3



VAF Instruments B.V.
Vierlinghstraat 24, NL-3316-EL Dordrecht
P.O. Box 40, NL-3300 AA Dordrecht
The Netherlands
Telephone: +31 78 618 3100
Fax: +31 78 617 7068
Internet: www.vaf.nl
E-mail: sales@vaf.nl

Specifications subject to change without notice.
Agents and distributors in more than 50 countries.



Represented by:

V A F I N S T R U M E N T S T O B E R E A L L Y S U R E